

## UVS - TR MALZEME NAKİL FANI (TAŞIMA) UVS - TR MATERIAL TRANSPORT FAN



### ÖZELLİKLERİ / SPECIFICATIONS

- Debi / Airflow : 1900 – 6000 m<sup>3</sup>/h
- Basınç / Pressure : 400 – 725 mm/ss
- Direkt akuple veya kayış kasnak tahrikli / Direct coupling or belt driven

### KULLANIM ALANLARI / AREAS OF USAGE

- Toz toplama / Collecting dust
- İnce tanecikli malzeme naklinde (mermer tozu, tahta tozu, granür, plastik vs.) / (marble dust, granule, plastique etc.)
- Matbaalarda, kağıt, mobilya, kereste, sunta, seramik ve mermer fabrikalarında / At printing houses different factories such as textile

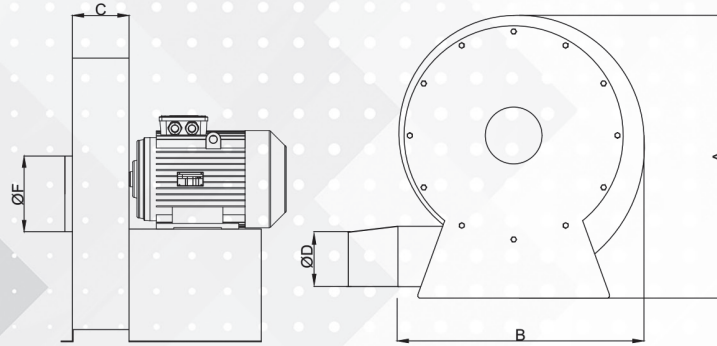

MODEL	POWER (KW)	RPM	AIRFLOW (m <sup>3</sup> /h)	PRESSURE (mm/ss)	A	B	C	D	FØ
UVS-TR5	2.2	2800	1900	400	580	650	120	120	140
UVS-TR6	3	2800	2200	450	660	690	150	150	150
UVS-TR7	4	2800	2500	500	670	720	150	150	150
UVS-TR8	5.5	2800	3000	600	740	650	150	150	150
UVS-TR9	7.5	2800	4000	725	770	740	180	180	180

All dimensions are in mm.